

ALLEZ

E5 DISC

USER MANUAL

ENGLISH



CONTENTS

1. INTRODUCTION	2
1.1. WARRANTY	2
2. ALLEZ E5 DISC COMPONENTS	3
3. GEOMETRY	5
4. GENERAL INFORMATION ABOUT YOUR ALLEZ E5 DISC	7
4.1. INTENDED USE.....	7
4.2. STRUCTURAL WEIGHT LIMITS.....	7
5. GENERAL NOTES ABOUT MAINTENANCE	8
5.1. REPLACEMENT PARTS AND ACCESSORIES.....	8
6. GENERAL NOTES ABOUT ASSEMBLY	9
6.1. REQUIRED TOOLS & TORQUE SPECIFICATIONS	9
6.2. RACK & FENDER MOUNTS.....	10
6.3. RECOMMENDED TIRE PRESSURES.....	11
7. ASSEMBLING YOUR ALLEZ E5 DISC	11
7.1. BOTTOM BRACKET.....	11
7.2. INSTALLING THE SEATPOST	12
7.3. DETERMINING SADDLE HEIGHT	12
7.4. SHIFTING.....	13
7.5. DISC BRAKES.....	13
7.6. FORK & STEM ASSEMBLY	15

SPECIALIZED BICYCLE COMPONENTS

15130 Concord Circle, Morgan Hill, CA 95037 (408) 779-6229
0000187872_UM_R1 01/22

We may occasionally issue updates and addendums to this document. Please periodically check www.specialized.com or contact Rider Care to make sure you have the latest information. Info: www.specialized.com

1. INTRODUCTION

THIS USER MANUAL CONTAINS IMPORTANT INFORMATION. PLEASE READ CAREFULLY AND STORE IN A SAFE PLACE.

This manual was drafted in the English language and may have been translated into other languages as applicable.





This user manual is specific to your Specialized Allez E5 Disc bicycle and should be read in addition to the Specialized Bicycle Owner's Manual ("Owner's Manual"). It contains important safety, performance, and technical information, which you should read before your first ride and keep for reference. You should also read the entire Owner's Manual because it has additional important general information and instructions which you should follow. If you do not have a copy of the Owner's Manual, you can download it at no cost at www.specialized.com, or obtain it from your nearest Authorized Specialized Retailer or Specialized Rider Care.

Please note all instructions and notices are subject to change and updates without notice. Please visit www.specialized.com for periodic tech updates.

Additional safety, performance, and service information for specific components such as suspension or pedals on your bicycle, or for accessories such as helmets or lights may also be available. Make sure that your Authorized Specialized Retailer has given you all the manufacturers' literature that was included with your bicycle or accessories. In case of a conflict between the information in this user manual and information provided by a component manufacturer, please contact your nearest Authorized Specialized Retailer.

ADDITIONAL LANGUAGES ARE AVAILABLE FOR DOWNLOAD AT www.specialized.com.

When reading this user manual, you will note various important symbols and warnings, which are explained below:

	WARNING! The combination of this symbol and word indicates a potentially hazardous situation which, if not avoided, could result in serious injury or death. Many of the Warnings say "you may lose control and fall." Because any fall can result in serious injury or even death, we do not always repeat the warning of possible injury or death.
	CAUTION: The combination of the safety alert symbol and the word CAUTION indicates a potentially hazardous situation, which, if not avoided, may result in minor or moderate injury, or is an alert against unsafe practices.
	The word CAUTION used without the safety alert symbol indicates a situation which, if not avoided, could result in serious damage to the bicycle or the voiding of your warranty.
	This symbol alerts the reader to information which is particularly important.
	This symbol means that high-quality grease should be applied as illustrated.
	Tech tips are useful tips and tricks regarding installation and use.

1.1. WARRANTY

Please refer to the written warranty provisions provided with your bicycle, or visit www.specialized.com. A copy is also available at your Authorized Specialized Retailer.

2. ALLEZ E5 DISC COMPONENTS

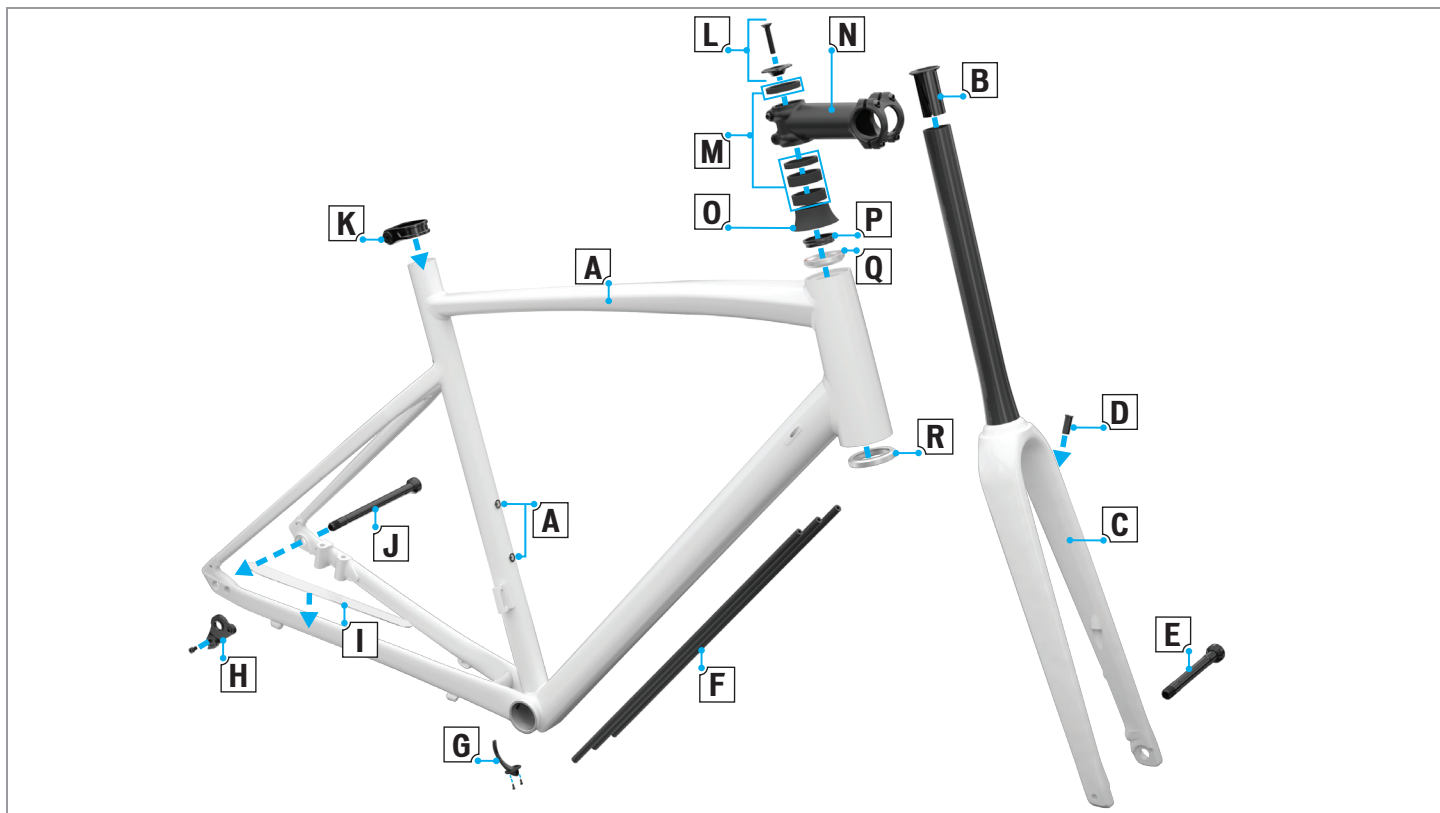

	PART #	DESCRIPTION
A	NA	FRAME
B	S142500007	EXPANDER PLUG
C	S222300001	FORK - SATIN
	S222300002	FORK - GLOSS
D	S179900014	FLAT ICR GROMMET
E	S180200004	FRONT THRU-AXLE
F	S149900018	FOAM CHURRO
G	S156500004	BOTTOM BRACKET CABLE GUIDE
H	S182600001	REAR DERAILLEUR HANGER
I	S206900001	CHAINSTAY PROTECTOR
J	S180200005	REAR THRU-AXLE
K	S164700002	SEATPOST CLAMP
L	NA	STEM TOP CAP
M	NA	SPACERS*
N	NA	STEM
O	NA	HEADSET COVER*
P	NA	COMPRESSION RING*
Q	S092500002	UPPER BEARING*
R	S102500902	LOWER BEARING*

*These components make up the headset (S132500004)

3. GEOMETRY

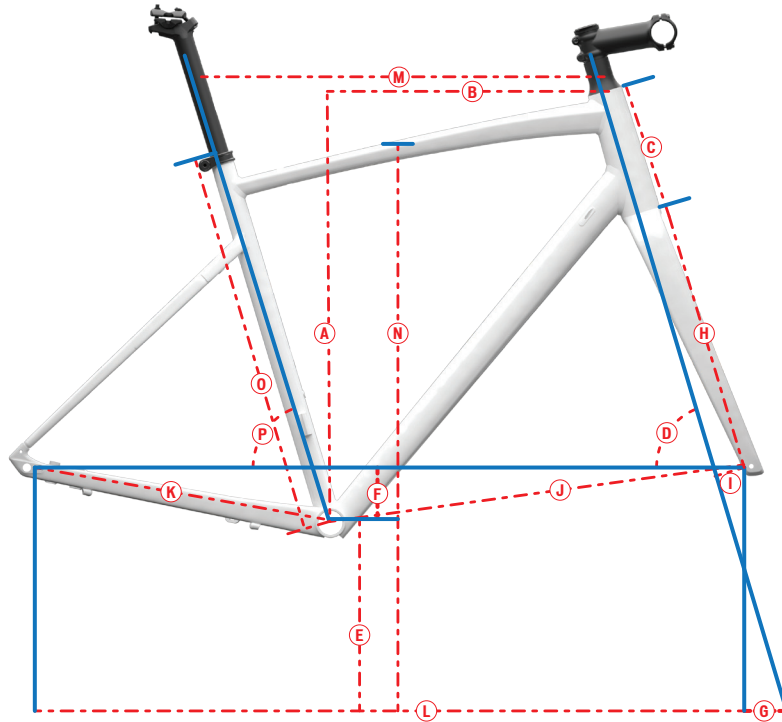

The geometry as summarized in this manual is current as of the date this manual was written and is subject to change. Specialized reserves the right to change the components at any time and without notice, including modifying, reducing, and/or adding features.

	FRAME SIZE	44	49	52	54	56	58	61
A	STACK (mm)	519	536	552	569	590	610	643
B	REACH (mm)	356	359	364	370	378	386	392
C	HEAD TUBE LENGTH (mm)	110	125	140	155	175	195	230
D	HEAD TUBE ANGLE (°)	69.5	70.5	71	72	72.5	73	73
E	BOTTOM BRACKET HEIGHT (mm)	273	273	273	274	274	275.5	275.5
F	BOTTOM BRACKET DROP (mm)	77	77	77	76	76	74.5	74.5
G	TRAIL (mm)	81	74	71	64	61	58	58
H	FORK LENGTH (FULL) (mm)	378	378	378	378	378	378	378
I	FORK RAKE/OFFSET (mm)	47	47	47	47	47	47	47
J	FRONT CENTER (mm)	576	577	583	585	594	603	619
K	CHAINSTAY LENGTH (mm)	420	420	425	425	425	425	425
L	WHEELBASE (mm)	984	984	995	998	1008	1017	1033
M	TOP TUBE LENGTH (mm)	493	500	530	541	556	569	586
N	STANDOVER HEIGHT (mm)	715	739	761	781	801	821	852
O	SEAT TUBE LENGTH (mm)	430	460	490	510	530	550	580
P	SEAT TUBE ANGLE (°)	75.25	75.25	73.25	73.25	73.25	73.25	73.25

4. GENERAL INFORMATION ABOUT YOUR ALLEZ E5 DISC

4.1. INTENDED USE

<p>HIGH-PERFORMANCE ROAD</p> 	<p>Bicycles designed for riding on a paved surface where the tires do not lose ground contact. These bicycles are intended to be ridden on paved roads only. The bicycles are NOT intend for off-road, cyclocross, or touring with racks and panniers.</p>
<p>TRADE OFF</p>	<p>Material use is optimized to deliver both light weight and specific performance. You must understand that (1) these types of bicycles are intended to give an aggressive racer or competitive cyclist a performance advantage over a relatively short product life, (2) a less aggressive rider will enjoy longer frame life, (3) you are choosing light weight (shorter frame life) over more frame weight and a longer frame life, (4) you are choosing light weight over more dent resistant or rugged frames that weigh more. All frames that are very light need frequent inspection. These frames are likely to be damaged or broken in a crash. They are not designed to take abuse or be a rugged workhorse.</p>



For more information on the intended use and structural weight limits for the frame and components, please refer to the Owner's Manual.

4.2. STRUCTURAL WEIGHT LIMITS

MODEL	CARGO		STRUCTURAL (LB / KG)
	REAR (LB / KG)	FRONT (LB / KG)	
ALL MODELS	55 lb / 25 kg	N/A	275 lb / 125 kg

STRUCTURAL WEIGHT LIMIT: The maximum total weight (rider and cargo) a bike is designed and tested to support structurally.

CARGO WEIGHT LIMIT: The maximum cargo weight a bike has been designed and tested to support structurally.



WARNING! The specified cargo weight limit applies only to compatible front and rear racks and seat bags where indicated. In case the specified cargo weight limit differs from the cargo weight limit specified by the rack or seat bag manufacturer, always use the lowest limit. If you add any other load-bearing accessories, including, but not limited to, baskets and child carriers, you do so at your own risk in that these accessories have not been tested for compatibility, reliability, or safety on your bicycle. Failure to follow this warning may result in serious personal injury or death.



For more information on the intended use and structural weight limits for the frame and components, please refer to the Owner's Manual.

5. GENERAL NOTES ABOUT MAINTENANCE

The Allez E5 Disc is a high-performance bicycle. All regular maintenance, troubleshooting, repair, and parts replacement must be performed by an Authorized Specialized Retailer. For general information regarding the maintenance of your bicycle, please refer to the Owner's Manual. In addition, routinely perform a mechanical safety check before each ride as described in the Owner's Manual.

- Great care should be taken to not damage the frame material. Damage may result in a loss of structural integrity, which may result in a catastrophic failure. This damage may or may not be visible during inspection. Before each ride, and after any crash, you should carefully inspect your bicycle for any gouging, scratches through the paint, chipping, bending, or any other signs of damage. Do not ride if your bicycle shows any of these signs. After any crash, and before you ride any further, take your bicycle to an Authorized Specialized Retailer for a complete inspection.
- While riding, listen for any creaks as a creak can be a sign of a problem with one or more components. Periodically examine all surfaces in bright sunlight to check for any small hairline cracks or fatigue at stress points, such as welds, seams, holes, and points of contact with other parts. If you hear any creaks, see signs of excessive wear, discover any cracks, no matter how small, or any damage to the bicycle, immediately stop riding the bicycle and have it inspected by your Authorized Specialized Retailer.
- Exposure to harsh elements, especially salty air (such as riding near the ocean or in the winter), can result in galvanic corrosion of components such as the crank spindle and bolts, which can accelerate wear and shorten the lifespan. Dirt can also accelerate wear of surfaces and bearings. The surfaces of the bicycle should be cleaned before each ride. The bicycle should also be maintained regularly by an Authorized Specialized Retailer, which means it should be cleaned, lubricated, and (partially) disassembled and inspected for signs of corrosion and/or cracks. If you notice any signs of corrosion or cracking on the frame or any component, the affected item must be replaced.
- Regularly clean and lubricate the drivetrain according to the drivetrain manufacturer's instructions.
- Do not use a high pressure water spray to wash your bicycle. Even water from a garden hose can penetrate seals and water may seep into components, such as cranks, bearings, or electrical components, potentially causing damage. Use a clean, damp cloth and bicycle cleaning agents (where appropriate) for cleaning.

- Do not expose the bicycle to prolonged direct sunlight or excessive heat, such as inside a car parked in the sun or near a heat source such as a radiator.



WARNING! Failure to follow the instructions in this section may result in damage to the components on your bicycle and will void your warranty, but, most importantly, may result in serious personal injury or death. If your bicycle exhibits any signs of damage, do not use it and immediately bring it to your Authorized Specialized Retailer for inspection.



WARNING! Use a repair stand to support the bicycle during assembly or maintenance, and a bicycle rack for transportation.

When placing the frame and/or bicycle in a repair stand, clamp the stand to the seatpost and not the frame. Clamping the frame can cause damage to the frame that may or may not be visible, and you may lose control and fall.

5.1. REPLACEMENT PARTS AND ACCESSORIES

Specialized replacement parts and accessories are available through your Authorized Specialized Retailer.

6. GENERAL NOTES ABOUT ASSEMBLY

This manual is not intended as a comprehensive assembly, use, service, repair or maintenance guide. Please see your Authorized Specialized Retailer for all service, repairs, or maintenance. Your Authorized Specialized Retailer may also be able to refer you to classes, clinics or books on bicycle use, service, repair, and maintenance.

- The Allez E5 Disc models are equipped with standard eyelets for front and rear fenders and rear racks.
- Allez E5 Disc forks are not compatible with crown-mounted cargo racks, such as the Specialized Pizza Rack.
- Tire sizes vary significantly from brand to brand. CEN standards require a minimum of 6mm of clearance between the frame/fork and the tires. When choosing a wheel and tire combo, factor in enough clearance for the conditions, setup and wheel flex.



WARNING! Due to the high degree of complexity of the Allez E5 Disc, proper assembly requires a high degree of mechanical expertise, skill, training and specialty tools. Therefore, it is essential that the assembly, maintenance and troubleshooting be performed by an Authorized Specialized Retailer.



WARNING! Some components on the Allez E5 Disc are proprietary to the Allez E5 Disc. Only use originally supplied components and hardware at all times. Use of other components or hardware will compromise the integrity and strength of the assembly. Allez E5 Disc specific components should only be used on the Allez E5 Disc and not on other bicycles, even if they fit. Failure to follow this warning could result in serious injury or death.



WARNING! Never modify your frame or components in any way. Do not sand, drill, file, or remove parts. Do not install incompatible forks or components. An improperly modified frame, fork, or component, can cause you to lose control and fall.

6.1. REQUIRED TOOLS & TORQUE SPECIFICATIONS



For all non-Specialized components, please refer to the manufacturer's manuals for tools and torque settings.



CAUTION: Ensure that all contact surfaces are clean and bolt threads are greased or have a threadlocker compound (refer to the instructions for each bolt) prior to installation.



Many bolts have a blue threadlocker patch on the threads to help secure the bolt under torque. Repeated installation and removal of a bolt may reduce the effectiveness of the patch. However, it can be replaced with the application of a liquid blue threadlocker.



WARNING! Correct tightening force on fasteners (nuts, bolts, screws) on your bicycle is important for your safety. If too little force is applied, the fastener may not hold securely. If too much force is applied, the fastener can strip threads, stretch, deform or break. Either way, incorrect tightening force can result in component failure, which can cause you to lose control and fall.

Where indicated, ensure that each bolt is torqued to specification. After your first ride, and consistently thereafter, recheck the tightness of each bolt to ensure secure attachment of the components. Following is a summary of torque specifications in this manual.

2, 2.5, 3, 4, 5, 6 mm hex bits	High-quality grease
Torque wrench	Blue threadlocker
Phillips screwdriver	

LOCATION	TOOL	TORQUE	
		Nm	in-lbf
WATER BOTTLE / ACCESSORY BAG BOLTS	3 mm HEX	3	27
REAR DISC BRAKE MOUNTS	4 mm HEX	8	71
REAR THRU-AXLE	6 mm HEX	15	133
REAR DERAILLEUR HANGER BOLT	4 mm HEX	4.5	40
SEATPOST CLAMP BOLT	5 mm HEX	6.2	55

FRONT DISC BRAKE MOUNTS	4 mm HEX	8	71
FRONT THRU-AXLE	6 mm HEX	15	133
STEM STEERER BOLTS	4 mm HEX	5	44
STEM FACEPLATE BOLTS	4 mm HEX	5	44
EXPANDER PLUG	6 mm HEX	9	80
BB CABLE GUIDE	PHILLIPS	1.5	13.5

6.2. RACK & FENDER MOUNTS

For more information on fender and rack installation, please see an Authorized Specialized Retailer.

REAR RACK

An optional rear rack can be fit to the bicycle using dropout and seat clamp mounting hardware. Make sure to follow the manufacturer's instructions when installing.



WARNING! A rear rack can be attached to the back end of your bicycle, and as a result, a proper and secure installation by your Authorized Specialized Retailer is critical for your safety. Only use original hardware at all times. Improper installation or adjustment may result in an accident, which can cause serious personal injury.



WARNING! Racks and baskets, especially when loaded, affect the handling of your bicycle by altering the center of gravity, weight, and balance. Before your first ride, you should practice riding in a controlled environment.

FENDERS

Optional front and rear fenders can be fit to the bicycle. Make sure to follow the manufacturer's instructions when installing.

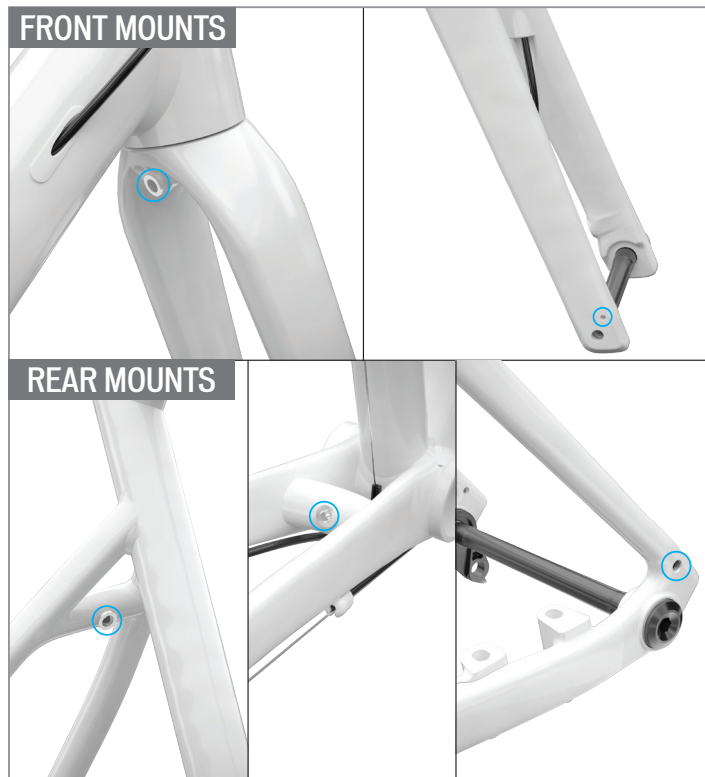

6.3. RECOMMENDED TIRE PRESSURES

The tires must be inflated and periodically checked and re-inflated using a pump with an accurate pressure gauge.

Pump the tires up to your desired pressure. Refer to the tire's sidewall for pressure range. Check your wheel manual or decal on the rim itself to see if your wheels have a maximum pressure limit. Do not exceed it.



WARNING! Never inflate a tire beyond the maximum pressure marked on the tire's sidewall or the maximum pressure limit specified by the wheel manufacturer, whichever is lower. Failure to follow this warning may cause the tire to blow off the rim and may result in serious personal injury.

7. ASSEMBLING YOUR ALLEZ E5 DISC

7.1. BOTTOM BRACKET

The Allez E5 Disc frame uses a 68 mm standard BSA threaded design. Grease the threads. Install and torque according to the bottom bracket manufacturer's instructions.

Before installing the bottom bracket and crank, make sure all housings and wires are routed through the frame.



CAUTION: Do not face the bottom bracket shell! This can prevent proper installation of the crank. Your Specialized frame does not require any bottom bracket shell pre-installation preparation, as all surfaces have been precisely machined to specific tolerances at the factory for proper interface with a compatible crankset. Please refer to the manufacturer instructions for crank and bottom bracket installation.



CAUTION: Always use a bottom bracket equipped with a sleeve between the two cups. Running a bottom bracket without the sleeve can result in housings and/or wires contacting the bottom bracket spindle, which can result in wear.

7.2. INSTALLING THE SEATPOST

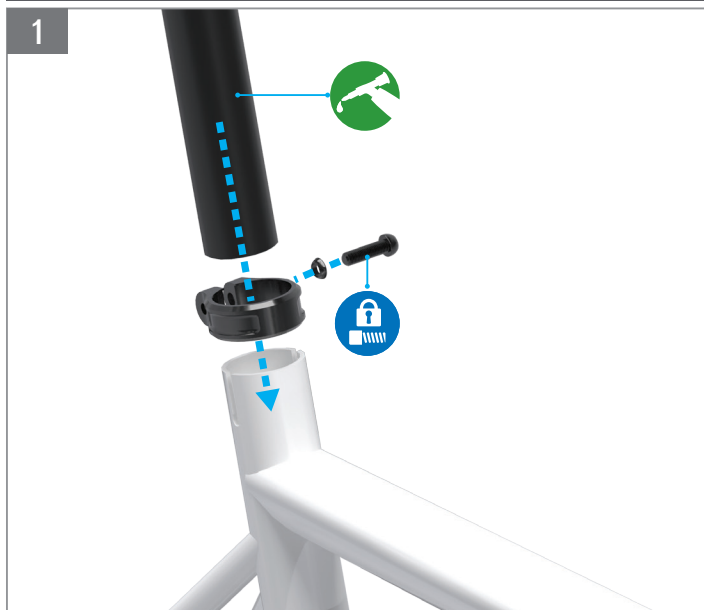

FIG. 1

- Make sure the seatpost clamp bolt is facing toward the back of the bicycle.
- Apply grease, then insert the seatpost into the seat tube.
- Apply threadlocker to the seatpost clamp bolt, then use a 4 mm hex key to torque the bolt to 6.2 Nm / 55 in-lbf.

7.3. DETERMINING SADDLE HEIGHT

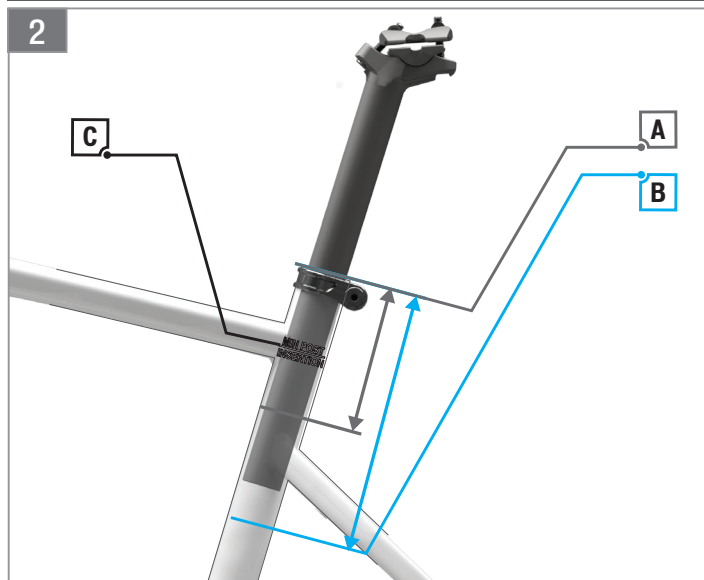

FIG. 2

- **MINIMUM INSERTION (A):** To prevent damage to the frame and/or seatpost, it's important to have a minimum amount of seatpost insertion in the seat tube. This minimum insertion must meet the following requirements:
 - The seatpost must be inserted into the frame deep enough so the minimum insertion/maximum extension (min/max) mark (C) on the seatpost is not visible.
 - The seatpost must be inserted into the seat tube deep enough to meet or exceed the 100 mm minimum measure insertion depth required by the frame.

- If the seatpost and frame minimum insertion requirements differ from each other, always use the longer minimum insertion. For example, if the frame requires 90 mm, but the seatpost requires 100 mm, then 100 mm is the minimum insertion required.
- If the seatpost is at the min/max mark but doesn't meet or exceed the minimum measured insertion depth of the frame, you should lower the seatpost until it meets or exceeds the frame insertion requirement. If this results in the saddle being too low, the seatpost must be replaced with a longer seatpost.
- **MAXIMUM INSERTION (B):** The seat tube is reamed to a specified maximum insertion depth which varies for each frame size. This ream depth limits the insertion depth of the seatpost. Please refer to the MIN/MAX SEATPOST INSERTION table.
- If the post is at the maximum insertion and the saddle is not at the desired position, the seatpost must be replaced with a shorter seatpost.
- Once the saddle height is determined, use a torque wrench and 5 mm hex bit to torque the supplied seatpost clamp bolt to 6.2 Nm / 55 in-lbf.

MIN/MAX SEATPOST INSERTION							
FRAME SIZE	44	49	52	54	56	58	61
MIN INSERTION (mm)	100	100	100	100	100	100	100
MAX INSERTION (mm)	185	205	235	255	275	295	325



WARNING! Failure to follow the seatpost and frame insertion requirements may result in damage to the frame and/or seatpost, which could cause you to lose control and fall.

If the seatpost is cut short, the min/max mark on the seatpost may no longer be accurate. Before cutting the seatpost, note the min/max depth required by the seatpost manufacturer.



WARNING! For general instructions regarding the installation of the seatpost, refer to the appropriate section in the Owner's Manual. Riding with an improperly tightened seatpost can allow the saddle and seatpost to slide down, which can damage the frame and cause you to lose control and fall.

7.4. SHIFTING

FIG. 3

- Route the rear derailleur housing (green)
 - Route the housing starting at the down tube ICR port then out of the hole at the bottom bracket.
- Route the front derailleur housing (violet)
 - Route the housing starting at the down tube ICR port then down to the bottom bracket cable stop.

7.5. DISC BRAKES

FIG. 3

- Route the rear brake housing (yellow)
 - Route the brake line starting at the down tube ICR port and out of the hole at the bottom bracket. Use a zip tie to fasten the brake housing to the chainstay at the housing tab.
 - Install the caliper on the chainstay. Torque the caliper bolts according to the brake manufacturer's instructions.
- Route the front brake housing (red)
 - Run the front brake housing in through the lower ICR port in the fork and guide it up in the fork leg until it exits at the upper ICR port.
 - Install the caliper on the fork leg. Torque the caliper bolts according to the brake manufacturer's instructions.
 - Install the housing grommets into the fork ICR ports.

3 SHIFTING & BRAKES



7.6. FORK & STEM ASSEMBLY

- Install the front end (fork, headset, headset spacers, stem, handlebar, wheels) on the frame then determine the rider's fit. Don't install more than 30 mm of spacers between the stem and the headset cover (FIG. 6).
- Trim the steerer tube so the final cut is 3 mm below the top of the stem (or 3 mm below the top of the spacer if a 5 mm spacer is used).

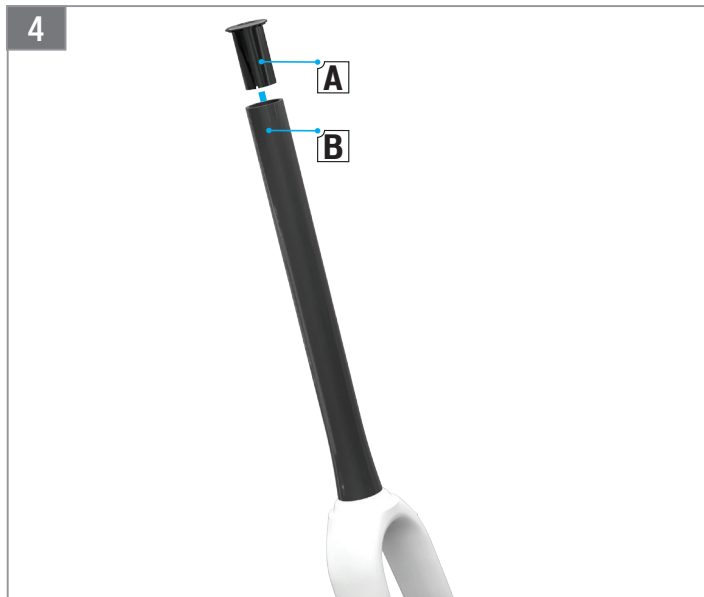

FIG. 4

- Install the expander plug (A) into the steerer tube (B). Using a 6 mm hex bit, torque the plug to 9 Nm / 80 in-lbf.

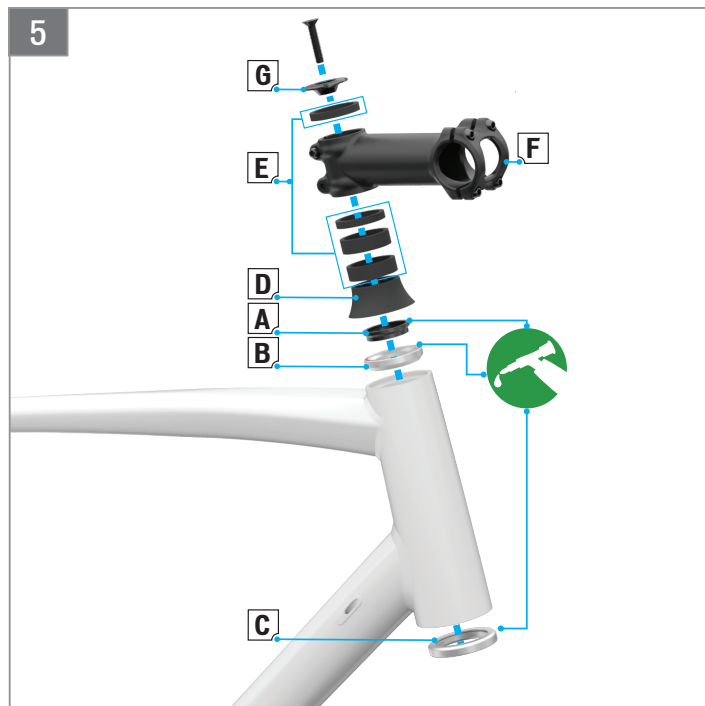



FIG. 5

- When installing the headset for the final assembly, grease the compression ring (A), the upper bearing (B), and the lower bearing (C).
- Install the headset cover (D), spacers (E) and stem (F), followed by the top cap and bolt (G). Using a 4 mm hex bit, torque the bolt to approximately 1-2 Nm / 9-18 in-lbf.

- With the bike on the ground, pull the front brake and rock the bike forward and backward to ensure the headset is fully seated and that there is no looseness or binding in the system. Tighten or loosen the top cap bolt (G) as needed to adjust the headset preload.
- Once the headset is fully adjusted, torque the stem steerer bolts to 5 Nm / 44 in-lbf.

 Once you've installed the handlebar, make sure the stem faceplate bolts are also torqued to 5 Nm / 44 in-lbf.

 Make sure to determine the appropriate rider stem height before cutting the steerer tube. Ideally, the steerer tube should be cut 3 mm below the top of the stem. Alternatively, one optional 5 mm solid spacer may be placed above the stem (FIG. 6). In that case, the steerer tube should be cut 3 mm below the 5 mm solid spacer.

 **WARNING!** The stem must be fully supported by the expander plug. Do not place more than one 5 mm solid spacer above the stem. In addition, the combined height between the stem and optional 5 mm spacer (from bottom of stem to top cap) must not exceed 45 mm. This is important if the originally equipped stem is changed with an aftermarket one. Exceeding 45 mm or placing more than one 5mm solid spacer above the stem may cause the stem to crush the steerer tube which may result in serious injury or death.

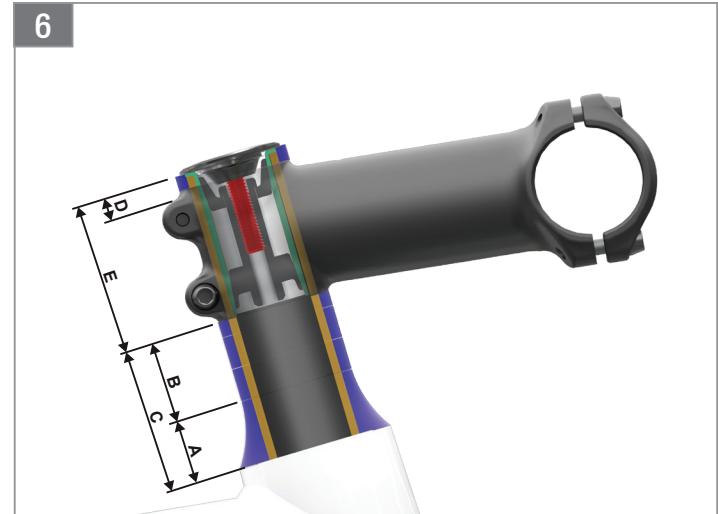

FIG. 6

- The headset cover (A) measures 20 mm thick. The maximum spacer stack height (B) between the headset cover and the stem is 30 mm, for a total of 50 mm (C).
- The maximum combined height of the stem's steerer tube clamp and any spacers placed above the stem (D; max 5 mm) must not exceed 45 mm (E).